

High-intensity Cup Horn

Description:

Branson's water-jacketed cup horn ultrasonically processes samples in a test tube or a sealed vessel, thereby isolating the horn from the solution. One-piece solid titanium construction is utilized, allowing isolation of samples for treatment.

High-intensity cavitation is possible due to the horn's concaved shape. This design permits disruption of many cells and is used for emulsification, dispersion, creation of lipid vesicles, suspension, homogenization, and degassing.

Approximate overall length: 7" (180mm)
 Body diameter: 3-9/16" (91mm)
 Cavity size: 1-3/4" (43mm)
 Coolant port size: 1/8 NPT

Nalgon fitting for the coolant port is supplied.

Typical Applications:

- Blood chemistry
- Lipid vesicle preparation
- Tablet dispersion
- Waste homogenization
- HPLC solvent degassing
- Pigment dispersion
- Tissue culture
- Infectious solutions

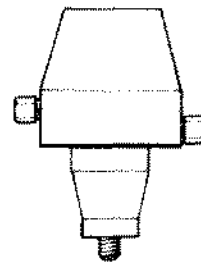
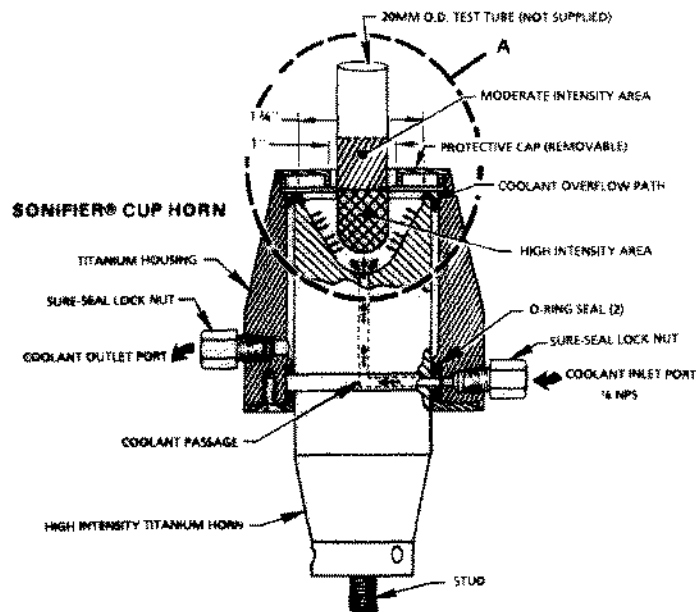

← HIGH-INTENSITY CUP HORN FOR PROCESSING SINGLE SEALED VESSELS (Part No. 101-147-046)



← CONVERTER receives electrical energy from power supply and converts to 20,000 Hz mechanical vibration. (Part No. 101-135-022)



POWER SUPPLY converts standard 60 Hz line voltage to high frequency electrical power of 20,000 Hz.

400 watts Model 450

